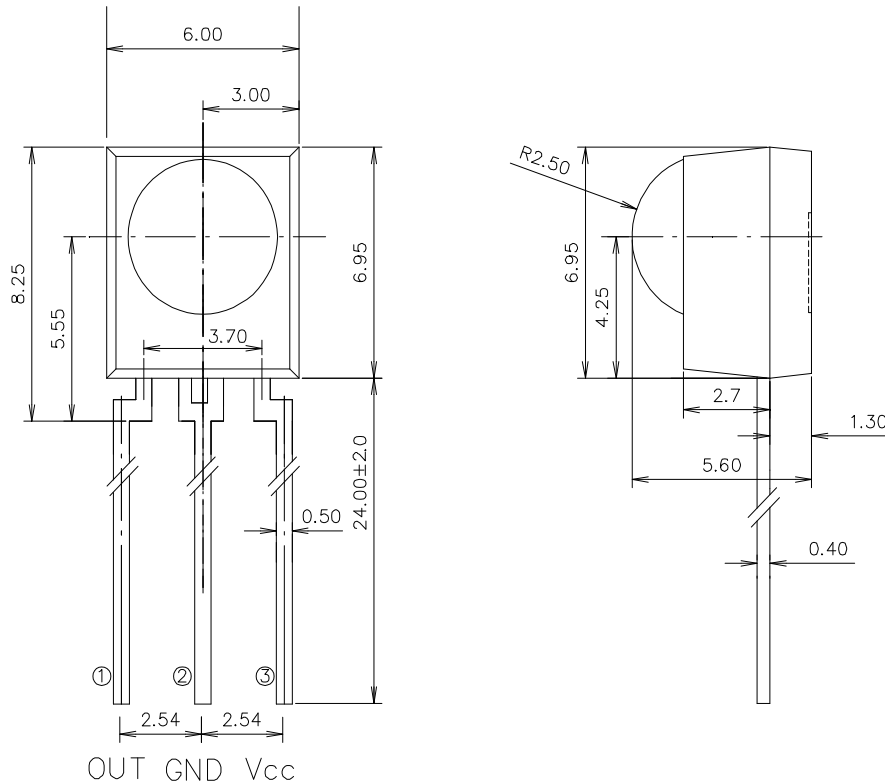

**Features**

- Receiver Module
- Internal filter for PCM frequency
- Output active low
- Photo detector and preamplifier in one package.
- Meet ROHS Green Product

**Applications**

- Receiver

**Package Dimensions****Notes:**

1. All dimensions are in millimeters (inches).
2. Tolerance is  $\pm 0.3$ mm unless otherwise noted.
3. Specifications are subject to change without notice
4. This drawing is only for indication, not as a basis for the actual structure.



**Selection Guide**

Part No	Carrie Frequencies	PART	MATERIAL	COLOR
FDI-M6069560R538-ZG	38 kHz	Chip	Silicon	Black
		Compound	Epoxy	Black

**Electrical / Optical Characteristics At Ta=25°C**

Symbol	Parameter	Ratings			Unit	Condition
		Min.	Typ.	Max		
V <sub>H</sub>	High Level Output Voltage	2.7			v	
V <sub>L</sub>	Low Level Output Voltage		0.2	0.5	v	
L	Reception Distance	15			m	θ=0° (Note 1)
		6			m	θ=45° (Note 1)
V <sub>cc</sub>	Supply Voltage	2.7	3	5.5	v	-
I <sub>cc</sub>	Consumption Current			2	mA	No signal input
λ <sub>Peak</sub>	Peak Wavelength		940		nm	
θ <sub>h</sub>	Half Angle		45		deg	-
T <sub>H</sub>	High Level Pulse Width	400		750	us	Note 2
T <sub>L</sub>	Low Level Pulse Width	400		750	us	

Note :

1. The ray receiving surface at a vertex and relation to the ray axis in the range of θ=0° and θ=45°.
2. A range from 30cm to the arrival distance. Average value of 50 pulses.

**Absolute Maximum Ratings At Ta=25°C**

Parameter	Maximum Rating	Unit
Supply Voltage	6.0	V
Supply Current	2.5	mA
Junction Temperature	80	°C
Operating Temperature Range	-20°C to + 85°C	
Storage Temperature Range	-40°C to + 80°C	
Soldering Condition	260°C For 5 Seconds (Note 1)	

Note 1 : 4mm from the bottom

Typical Characteristics (Ta=25°C unless otherwise specified)

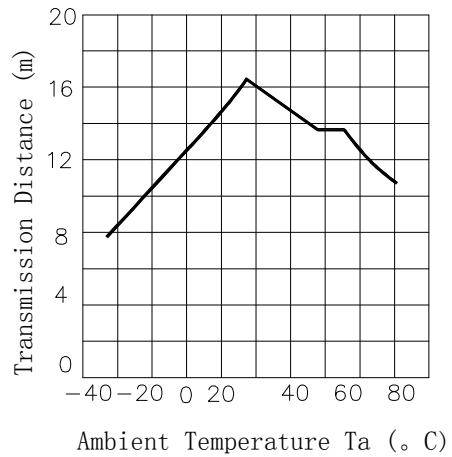
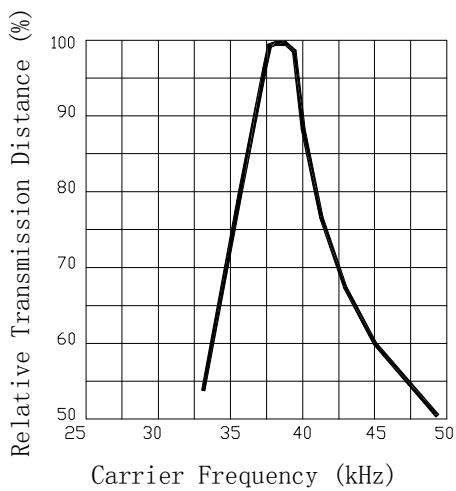
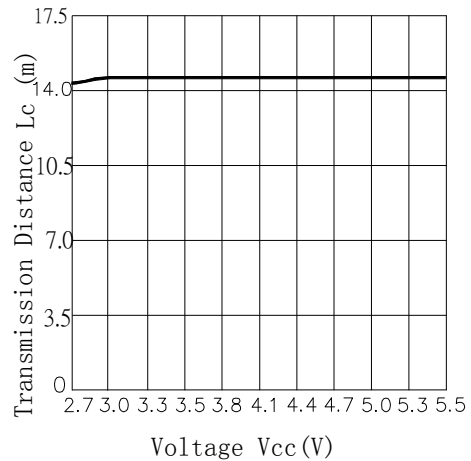
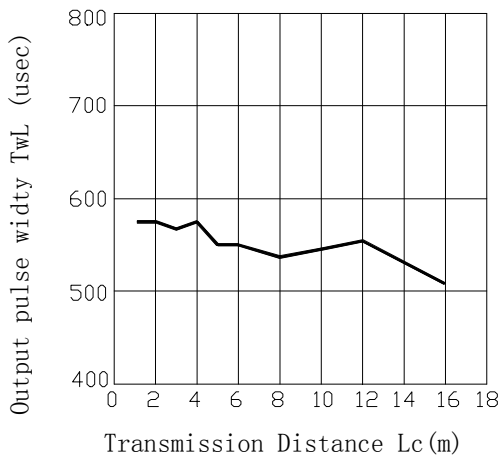
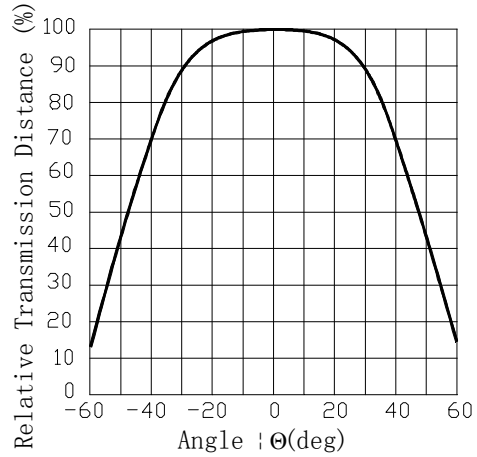
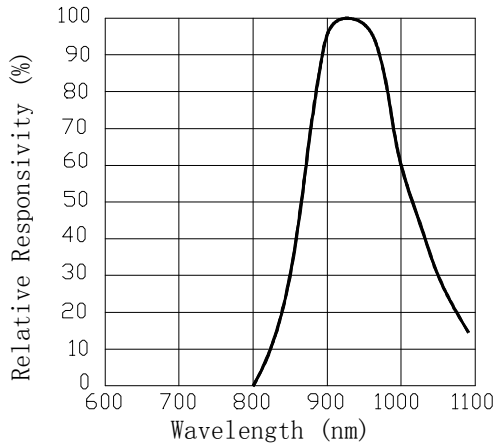

**Illustration of used terms**

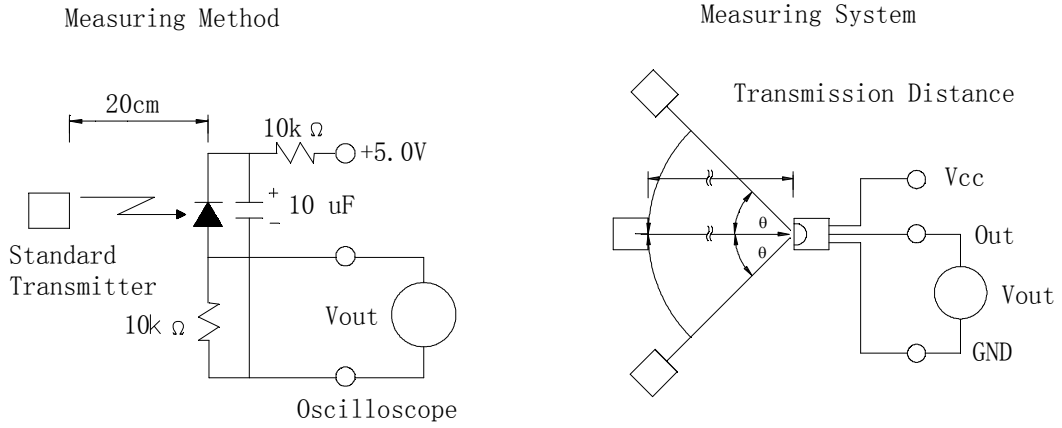

**Block Diagram**

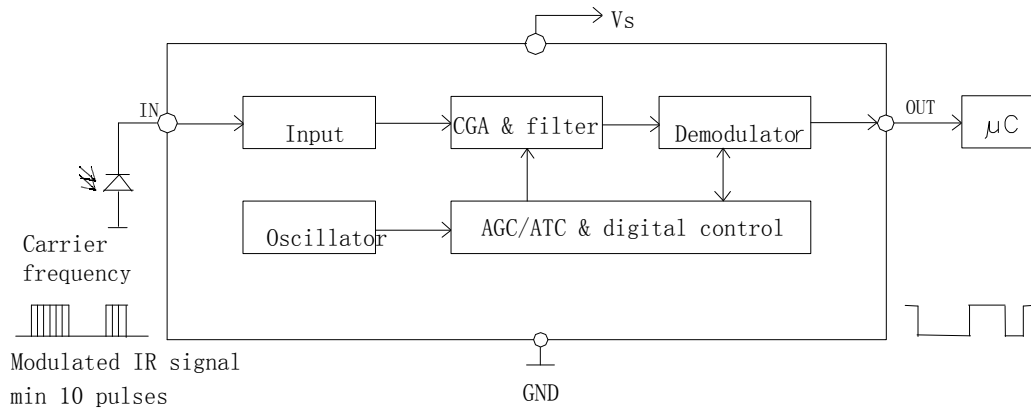

**Application Circuit**

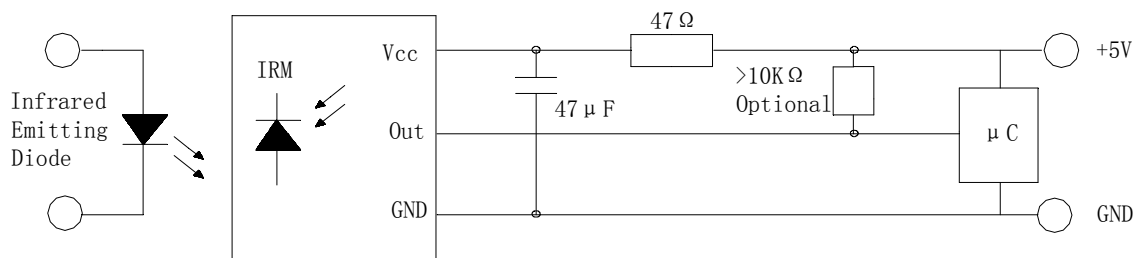

**Reliability Test Items Conditions**

Classification	Test Item	Test Conditions	Test hours	Result
Endurance Test	Opertion Life	Ta=Under room temperature	1000hrs	0/20
	Hige Temperature High Humidity	Ta=+ 65°C±5°C RH=85%	240hrs	0/20
	Hige Temperature Storage	High Ta=+ 85°C±5°C	1000hrs	0/20
	Low Temperature Storage	Low Ta=-35°C±5°C Test time=1000hrs	1000hrs	0/20
Environmental Test	Temperature Cycling	-40°C ~+100°C 15min 5min 15min	300 Cycles	0/20
	Thermal Shock	-35°C ~±5°C ~+85°C ~±5°C 5min 10sec 5min	300 Cycles	0/20
	Solder Resistance	Preheating: 120°C-150°C,within 2 minutes. Operation heating : 260°C(Max.),within5 seconds(Max.) 4mm from the bottom		0/20

**Judgment criteria of fialure for the reliability**

Measuring items	Symbol	Judement criteria for failure
Reception Distance ( $\theta=0^\circ$ )	L0	Below $S \times 0.7$
Reception Distance ( $\theta=45^\circ$ )	L45	Below $S \times 0.7$

Note: 1.U means the upper limit of specified characteristics. S means initial value.

2.Meansurment shall be taken between 2 hours after the test pieces have been returnde to normal ambient cnditions after completion of each test.