

Features

- 3mm DIA LED Lamp
- Low Power Consumption
- High Efficiency
- Various Colors and Viewing Angle
- Long Solid State Reliability
- Package: 1000pcs/Packing

Applications

- Indicator

Package Dimensions

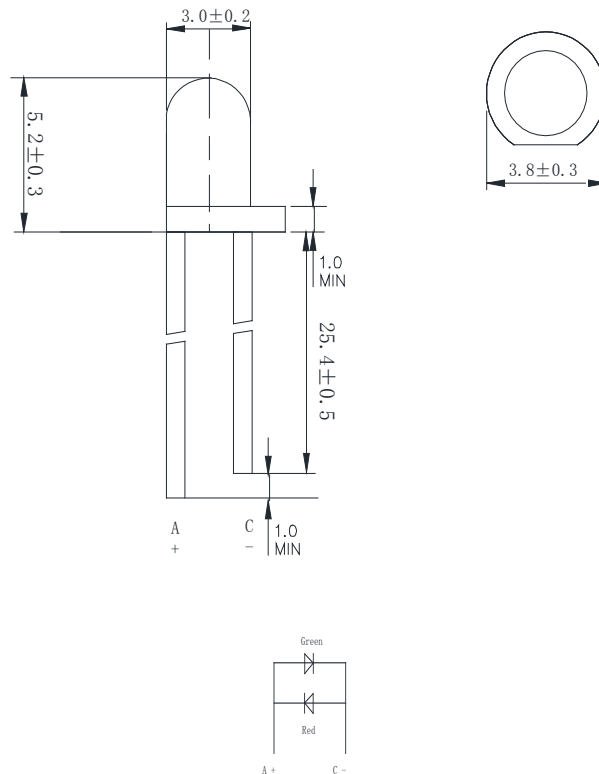

Notes:

1. All dimensions are in millimeters (inches).
2. Tolerance is ± 0.25 mm(.01") unless otherwise noted.
3. Protruded Resin under flange is 1.0mm(0.04") max.
4. Specifications are subject to change without notice.
5. This drawing is only for reference, not as a basis for the actual structure.



FDL-3522GR-TWD1

Selection Guide

Part No	Lens Type	Dice	Emitted Color
FDL-3522GR-TWD1	White Diffused	GaAsP	Red Green

Electrical / Optical Characteristics At Ta=25 °C

Symbol	Parameter	Min.	Typ.	Max.	Unit	Test Condition
Iv	Luminous Intensity		72/180		mcd	IF=20mA
2 θ 1/2	Viewing Angle		30/30		deg	IF=20mA
λ Peak	Peak Emission Wavelength		570/660		nm	IF=20mA
Δλ	Spectral Line Half-Width		30/20		nm	IF=20mA
VF	Forward Voltage		2.1/2.2	2.8/2.8	V	IF=20mA
IR	Reverse Current		50/50		uA	VR 5V

Note:

1. Right for red color.
Left for green color.
2. θ1/2 is the angle from optical centerline where the luminous intensity is 1/2 optical centerline value

Absolute Maximum Ratings At Ta=25°C

Parameter	Green	Red	Unit
Power Dissipation	80	80	mW
Peak Forward Current[1]	150	150	mA
Continuous Forward Current	30	30	mA
Reverse Voltage	5	5	V
Operating Temperature Range	-40°C to + 85°C		
Storage Temperature Range	-40°C to + 85°C		
Soldering Condition	260°C For 5 Seconds		

Note:

1. 1/10DutyCycle, 0.1ms Pulse Width

Electrical Optical Characteristics Curves At Ta=25 °C

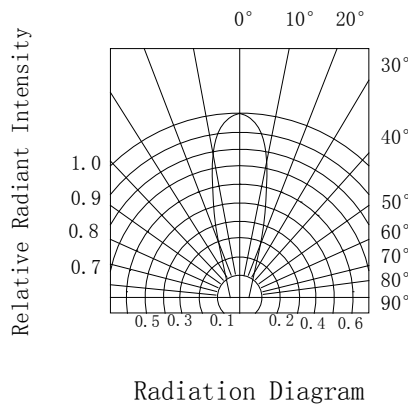
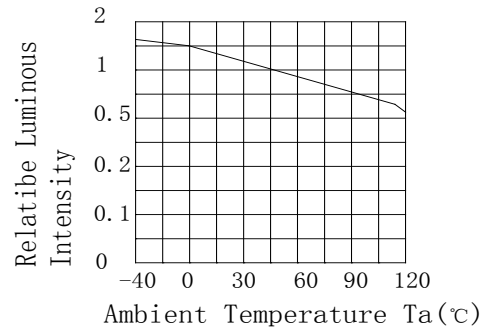
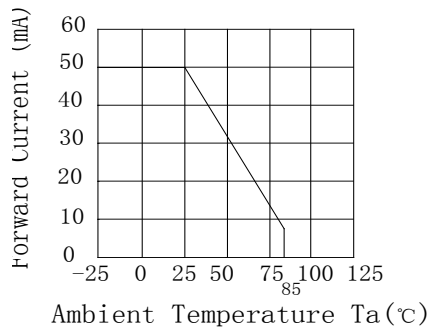
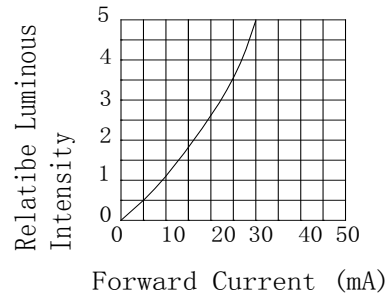
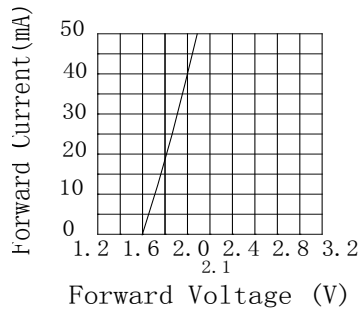
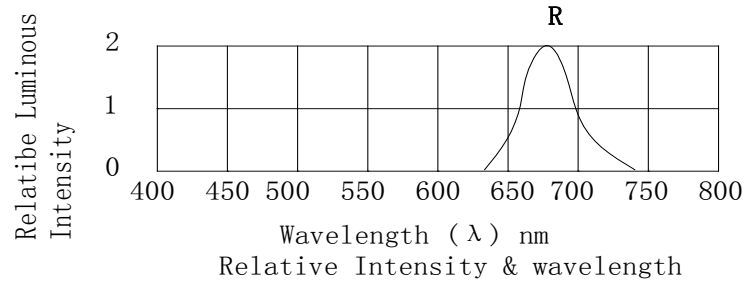

Electrical Optical Characteristics Curves At Ta=25 °C

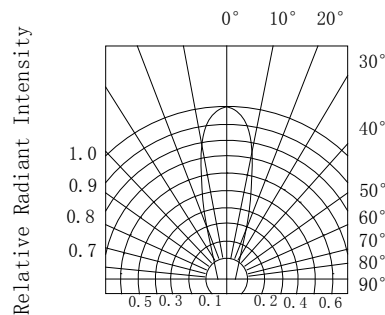
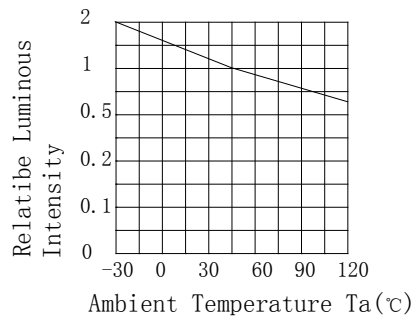
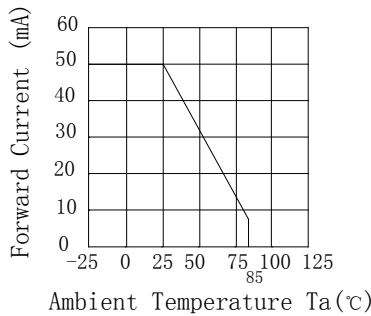
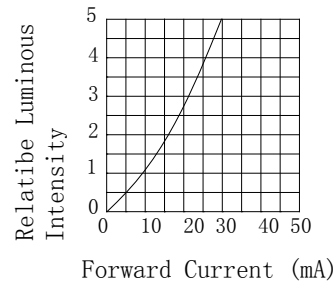
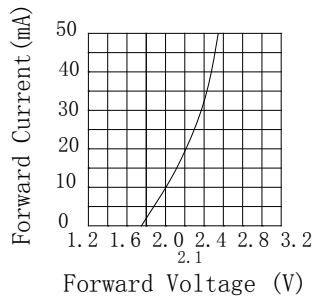
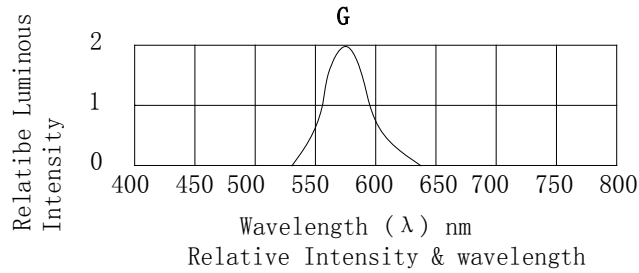

Radiation Diagram

Notes:

1. The LEDs should be used within a year.
2. The LEDs should be kept in 5~30°C and 60% RH for less.
3. The LEDs should be used within 24 hours, or else should be kept a 5~30°C and 30% RH or less. And LEDs should be used within 7 days after opening the package.