

**Features**

- 3mm DIA LED Lamp
- Low Power Consumption
- High Efficiency
- Various Colors and Viewing Angle
- Long Solid State Reliability
- Package: 1000pcs/Packing

**Applications**

- Indicator

**Package Dimensions**

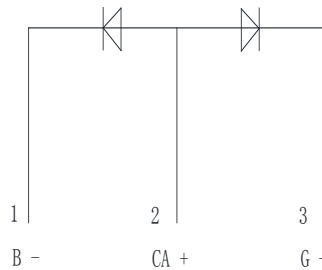
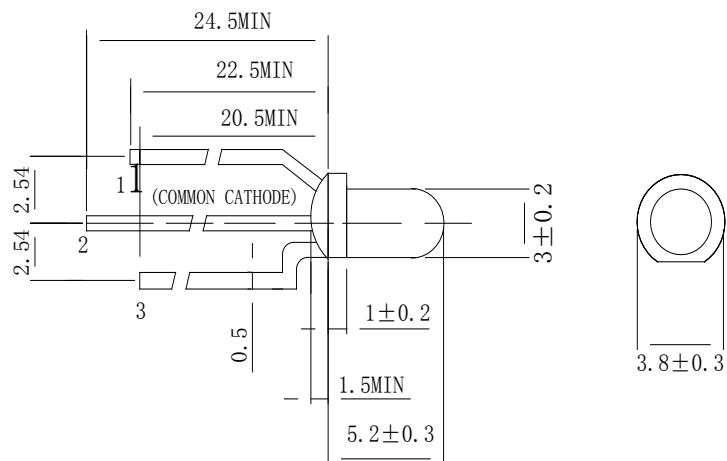

**Notes:**

1. All dimensions are in millimeters (inches).
2. Tolerance is ±0.25mm(.01") unless otherwise noted.
3. Protruded Resin under flange is 1.0mm(0.04") max.
4. Specifications are subject to change without notice.

www.FantasyLeds.com

Sales@FantasyLeds.com



**Selection Guide**

Part No	Lens Type	Dice	Emitted Color
FDL-3522PGB-TWC1DP-CA	White Clear	GaAsP	Blue Green

**Electrical / Optical Characteristics At Ta=25 °C**

Symbol	Parameter	Min.	Typ.	Max.	Unit	Test Condition
Iv	Luminous Intensity		70/90		mcd	IF=10mA
2 θ 1/2	Viewing Angle		30/30		deg	IF=20mA
λ Peak	Peak Emission Wavelength	455/560	460/565	465/570	nm	IF=20mA
Δλ	Spectral Line Half-Width	460/565	465/568	470/571	nm	IF=20mA
VF	Forward Voltage	2.8/2.8	3.0/3.0	3.5/3.5	V	IF=20mA
IR	Reverse Current		50/50		uA	VR 5V

Note:

1. Right for red color.  
Left for green color.
2. θ1/2 is the angle from optical centerline where the luminous intensity is 1/2 optical centerline value

**Absolute Maximum Ratings At Ta=25°C**

Parameter	Bule	Green	Unit
Power Dissipation	80	80	mW
Peak Forward Current[1]	150	150	mA
Continuous Forward Current	30	30	mA
Reverse Voltage	5	5	V
Electrostatic Discharge Threshold	300		V
Operating Temperature Range	-40°C to + 85°C		
Storage Temperature Range	-40°C to + 85°C		
Soldering Condition	260°C For 5 Seconds		

Note:

1. 1/10DutyCycle, 0.1ms Pulse Width

**Electrical Optical Characteristics Curves At Ta=25 °C**

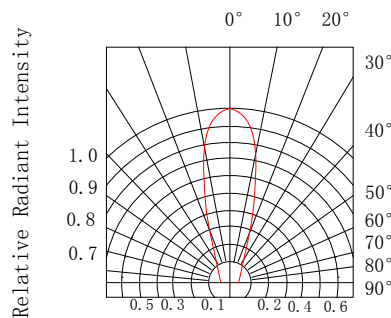
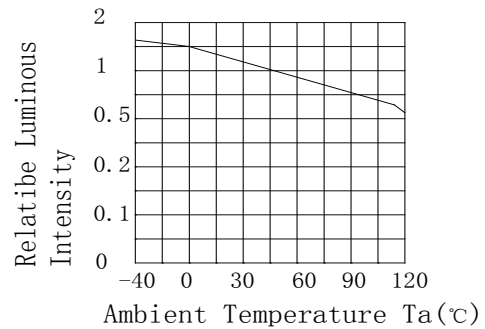
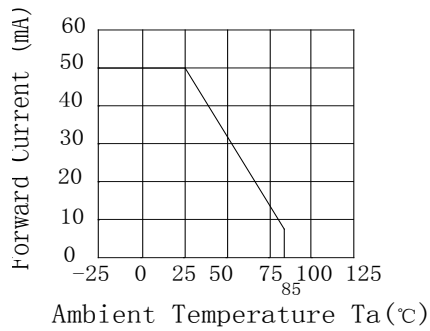
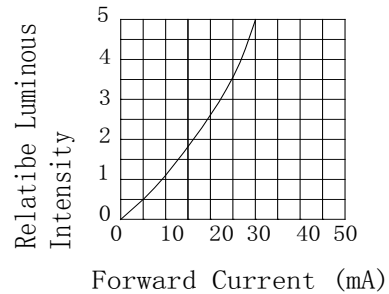
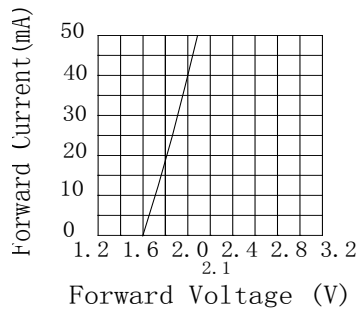
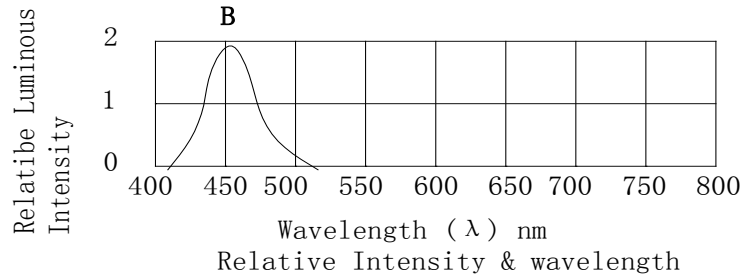

Radiation Diagram

**Electrical Optical Characteristics Curves At Ta=25 °C**

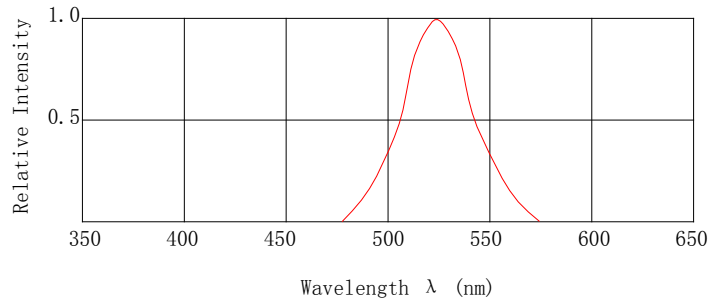

Fig.1 Relative Intensity vs. Wavelength

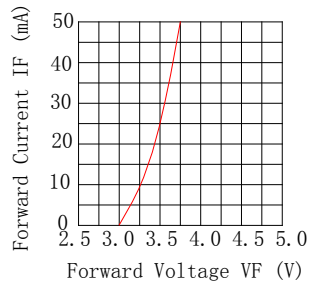

Fig.2 Forward Current VS. Forward Voltage

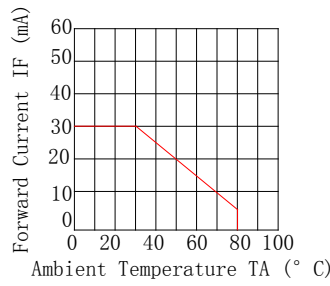

Fig.3 Forward Current Derating Curve

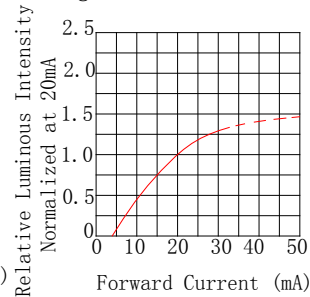

Fig.4 Relative Luminous Intensity VS. Forward Current

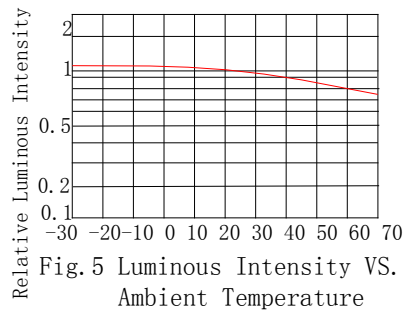

Fig.5 Luminous Intensity VS. Ambient Temperature

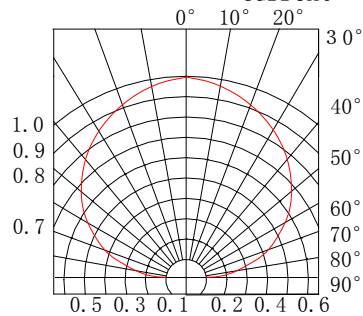
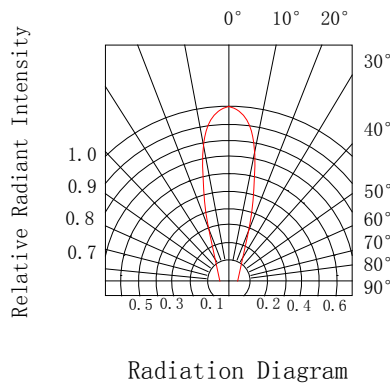

Fig.6 Spatial Distribution



Radiation Diagram

Notes:

1. The LEDs should be used within a year.

**Reliability Test Items Conditions**

Classification	Test Item	Test Conditions	Test hours	Result
Endurance Test	Opertion Life	Connect with a power if=20mA Ta=Under room temperature	1000Hrs	0/20
	Hige Temperature High Humidity	Ta=+ 65°C±5°C RH=90%-95%	240Hrs	0/20
	Hige Temperature Storage	High Ta=+ 85°C±5°C	1000Hrs	0/20
	Low Temperature Storage	Low Ta=-35°C±5°C Test time=1000hrs	1000Hrs	0/20
Environmental Test	Temperature Cycling	-45°C ~+105°C 15min 5min 15min	300 Cycles	0/20
	Thermal Shock	-35°C ~±5°C ~+85°C ~±5°C 5min 10sec 5min	300 Cycles	0/20
	Solder Resistance	Preheating: 120°C-150°C,within 2 minutes. Operation heating : 260°C (Max.),within5 seconds(Max.)	5Cycles	0/20

**Judgment criteria of fialure for the reliability**

Measuring items	Symbol	Measuring conditions	Judement criteria for failure
Forward voltage	V <sub>F</sub> (V)	I <sub>F</sub> =20mA	Over U×1.2
Rvevrse current	I <sub>R</sub> (μA)	V <sub>R</sub> =5V	Over U×2
Luminous intensity	I <sub>v</sub> (mcd)	I <sub>F</sub> =20mA	Below S×0.5

Note: 1.U means the upper limit of specified characteristics. S means initial value.

2.Meansurment shall be taken between 2 hours after the test pieces have been returnde to normal ambient cnditions after completion of each test.