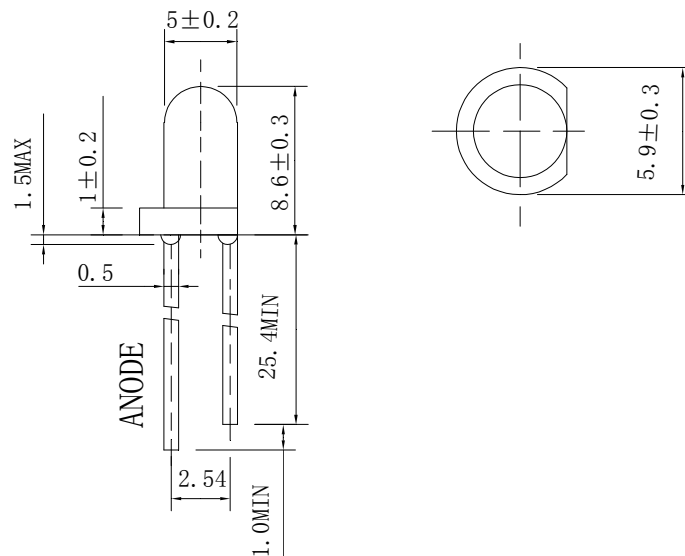

Features

- 5mm DIA LED Lamp
- Low Power Consumption
- High Efficiency
- Various Colors and Viewing Angle
- Long Solid State Reliability
- Package: 1000pcs/Packing

Applications

- Indicator

Package Dimensions**Notes:**

1. All dimensions are in millimeters (inches).
2. Tolerance is $\pm 0.25\text{mm}$ (.01") unless otherwise noted.
3. Protruded Resin under flange is 1.0mm (0.04") max.
4. Specifications are subject to change without notice.

**Selection Guide**

Part No	Lens Type	Dice	Emitted Color
FDL-503HRC-ZC1	Red Water Clear	GaAsP	High Red

Electrical / Optical Characteristics At Ta=25°C

Symbol	Parameter	Min.	Typ.	Max.	Unit	Test Condition
I _v	Luminous Intensity		100		mcd	IF=10mA
2θ _{1/2}	Viewing Angle		30		deg	IF=20mA
λ _{Peak}	Peak Emission Wavelength		660		nm	IF=20mA
λ _d	Dominant Wavelength		650		nm	IF=20mA
Δλ	Spectral Line Half-Width		20		nm	IF=20mA
V _F	Forward Voltage		2.0	2.5	V	IF=20mA
I _R	Reverse Current			50	uA	VR 5V

Note:

1. θ_{1/2} is the angle from optical centerline where the luminous intensity is 1/2 optical centerline value

Absolute Maximum Ratings At Ta=25°C

Parameter	Red	Unit
Power Dissipation	80	mW
Peak Forward Current[1]	150	mA
Continuous Forward Current	30	mA
Reverse Voltage	5	V
Operating Temperature Range	-40°C to + 85°C	
Storage Temperature Range	-40°C to + 85°C	
Soldering Condition	260°C For 5 Seconds	

Note:

1. 1/10DutyCycle, 0.1msPulseWidth

Electrical Optical Characteristics Curves At Ta=25°C

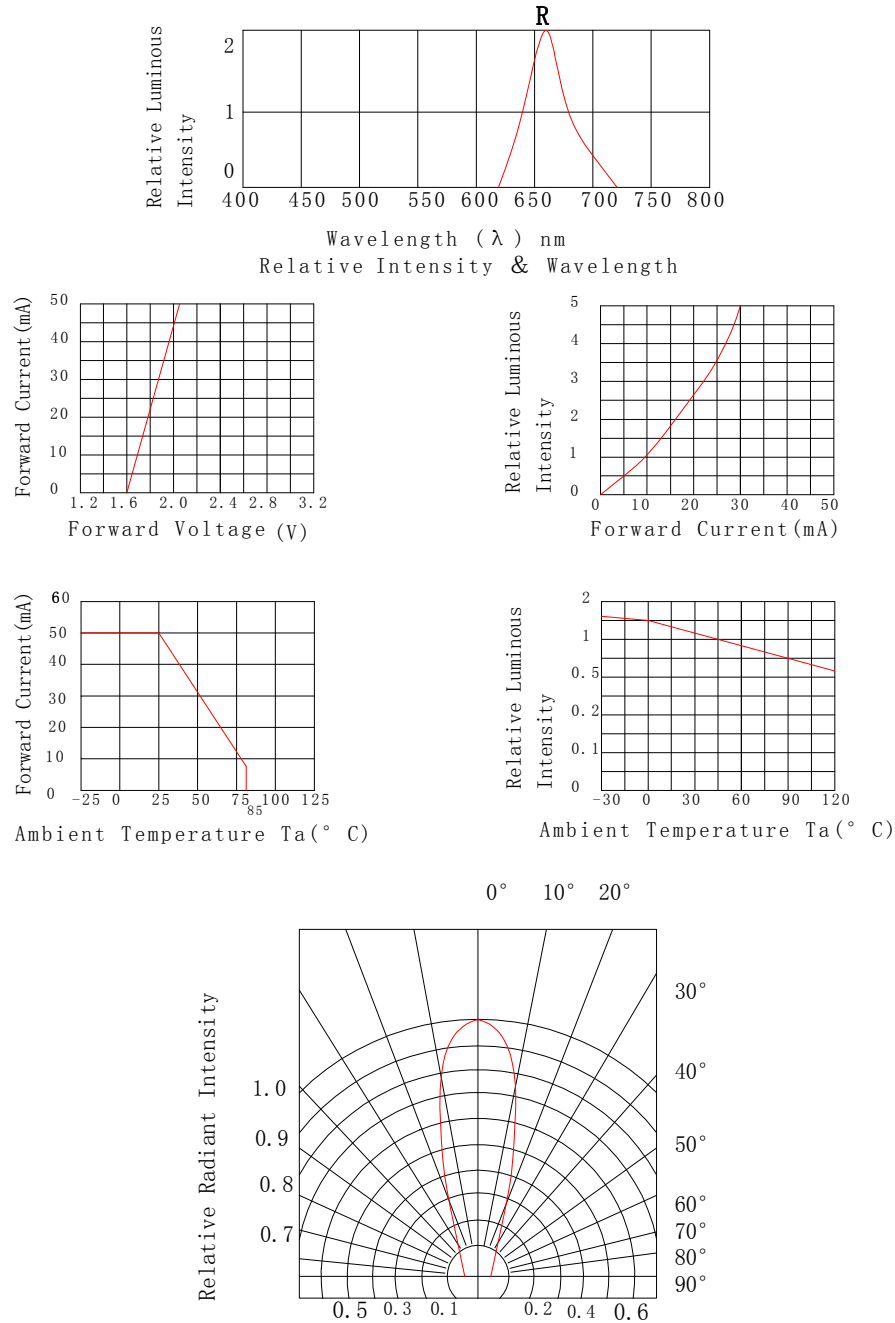

Fig. 6 Radiation Diagram

Notes:

1. The LEDs should be used within a year.
2. The LEDs should be kept in 5~30°C and 60% RH for less.
3. The LEDs should be used within 24 hours, or else should be kept a 5~30°C and 30% RH or less. And LEDs should be used within 7 days after opening the package.